

**CIS - Centrul pentru Iluminat cu Semiconductori (Semiconductors Lighting Center)**

**TECHNICAL SHEET  
 LED Luminary – CASTOR 6M**

|                                    |                           |
|------------------------------------|---------------------------|
| <b>Code</b>                        | <b>RS81455</b>            |
| <b>Application</b>                 | <b>Industrial</b>         |
| <b>Operating voltage</b>           | <b>230 V~</b>             |
| <b>Mains frequency</b>             | <b>50 Hz</b>              |
| <b>Power consumption</b>           | <b>196 W ± 10 %</b>       |
| <b>Power Factor (λ)</b>            | <b>&gt; 0.95</b>          |
| <b>Total Harmonic Distortions</b>  | <b>&lt; 11 %</b>          |
| <b>Insulation class</b>            | <b>I</b>                  |
| <b>Luminous Flux</b>               | <b>min. 21500 lm</b>      |
| <b>Color temperature (CCT)</b>     | <b>5400 K</b>             |
| <b>Color rendering index (IRC)</b> | <b>&gt; 80</b>            |
| <b>Optical / material</b>          | <b>lens C</b>             |
| <b>Ingress protection</b>          | <b>IP65</b>               |
| <b>Mechanical Shock</b>            | <b>IK10</b>               |
| <b>Operating temperature range</b> | <b>max. + 45 °C</b>       |
| <b>Weight</b>                      | <b>9.5 Kg</b>             |
| <b>Dimensions (L x W x H)</b>      | <b>550 x 425 x 312 mm</b> |

**Shape and dimensions:**

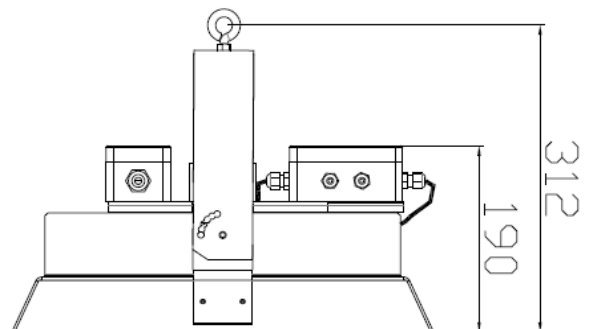
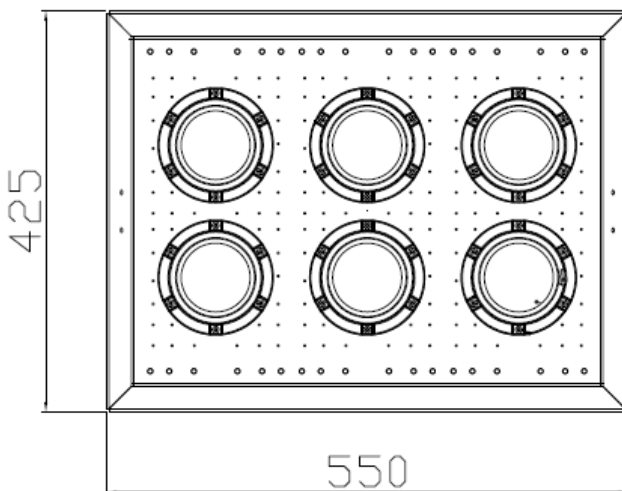

**Applicable Standards:**

- SR EN 60598-1:2009+A11:2009
- SR EN 60598-2-5:2001
- SR EN 62031:2009 art.13, 15
- SR EN 55015:2007+A1:2008+A2:2009
- SR EN 61000-3-2:2006+A1:2010+A2:2010
- SR EN 61000-3-3:2009
- SR EN 61547:2010